

S t u d e n t S u c c e s s

SHORELINE UNIFIED SCHOOL DISTRICT BOARD OF TRUSTEES SPECIAL MEETING

AGENDA

Friday, June 30, 2017 5:00 PM

**Shoreline Unified School District Office
10 John Street, Tomales CA**

We welcome you to this evening's meeting. The public may provide information and ask questions relevant to agenda items at the time those items are under consideration. We would appreciate if you identify yourself by name when addressing the Board. Speakers are limited to four minutes each. Copies of the agenda are located on the agenda table.

1. Formal opening and call to order 5:00 PM
2. Roll Call
3. Approval and Adoption of the Agenda
4. Flag Salute
5. Consider authorizing Superintendent Bob Raines to accept the best bid for the West Marin School septic repair project on the Board's behalf, not to exceed \$150,000. **ACTION**
6. Adjournment

SHORELINE UNIFIED SCHOOL DISTRICT

P.O. Box 198 Tomales, California 94971 (707) 878-2266 FAX: (707) 878-2554



June 30, 2017

To: The Board of Trustees, Shoreline Unified School District
From: Bob Raines, Superintendent
Re: Request for Authorization to Accept Bids for the West Marin School Septic Repair on Your Behalf

On June 21st, Bruce Abbott, Jim Lino, Matt Nagel and I met with Todd Lee of Greystone West, Troy Pearce of AYS Engineering, and Mike Giammona of City Sewer, at West Marin School to discuss a project to repair septic tanks and relocate a septic leech field at West Marin School.

At that meeting, it was determined that the project needed to proceed with some degree of alacrity due to the start of the 2017-18 School Year. At that time, we discussed the need to be able to solicit bids quickly and to be able to accept the best bid with the minimum of delay.

I have attached the following documents;

- Todd Lee's estimate of the project cost, including inspection costs and an allowance for unforeseen expenses
- The notice inviting bids
- The proposed project timeline
- A series of engineer's drawings of the proposed project
- The engineer's estimation of probable cost

This project will be managed under the Uniform Cost Accounting Procedures that you adopted at the March, 2017 Regular Meeting of the Board. Under those procedures, we are able to conduct an "informal" bid process, as the projected cost of the project falls under the threshold of \$175,000 for formal bids (Public Contract Code 22032).

With that in mind, I recommend that you authorize me or my designee to accept the best bid submitted for this project with the amount of the bid not to exceed \$150,000. This action would be in compliance with Public Contract Code 22034, which says, in part, "(e) The governing body of the public agency may delegate the authority to award informal contracts to the public works director, general manager, purchasing agent, or other appropriate person."

Thank you for your consideration.

From: Lee, Todd tlee@greystonewest.com
Subject: Re: West Marin School Septic
Date: June 27, 2017 at 2:59 PM
To: Bob Raines bob.raines@shorelineunified.org
Cc: Bruce Abbot bruce.abbott@shorelineunified.org



Hi Bob,

Advertisements are attached. I did see Troy's estimates and have to assume he knows better than I what the costs are. I can't say that I have priced any drip leach fields recently. I would put the Field 3 number at \$25,000 just to be safe. I would put the tank repairs at a not-to exceed of \$100,000. There will undoubtedly be some charges from Troy Pierce and possibly from the County for Inspections. I would say an all in budget of \$150,000 should be safe with expectations that it will be about half that. Also attached is a PDF of a proposed time line. It is conservative but with the unknowns, I think this is prudent. The tanks are fixed by the start of school. Field #3 runs a bit into the school year. With any luck, it will go faster than this.

Regards, Todd

On Tue, Jun 27, 2017 at 2:30 PM, Bob Raines <bob.raines@shorelineunified.org> wrote:

Hello Todd,

We are planning a very short board meeting on Friday afternoon so that the Board can give me authority to accept the best bid for the work at WMS.

Can you send me a copy of the advertisements?

And did you see Troy's cost estimates? Do you have any thoughts on them? Jim Lino and I were talking and we were trying to come up with some sort of a "not to exceed" number for the Board Meeting Agenda.

Finally, can you send me a very rough timeline to share with the Board?

Thanks

Bob Raines

Superintendent
Shoreline Unified School District
10 John Street
Tomales, CA 94971
[\(707\) 878-2266](tel:(707)878-2266)
bob.raines@shorelineunified.org

--

Todd Lee | **GREYSTONE WEST COMPANY**
621 West Spain Street, Sonoma, CA 95476
Cell: [707.479.9876](tel:707.479.9876) | Main: [707.933.0624](tel:707.933.0624) | Fax: [707.996.8390](tel:707.996.8390)
todd@greystonewest.com | www.greystonewest.com



West Marin
Elemen...ent.pdf



West Marin
Elemen...nt.docx

West Marin ES Septic Repairs																	
ID	Task Mode	Task Name	Duration	Start	J 11	J 18	J 25	J 2	J 9	J 16	J 23	J 30	A 6	A 13	A 20	A 27	S

NOTICE INVITING BIDS

1. Notice is hereby given that the Governing Board of the Shoreline Unified School District (“District”), of the County of Marin, State of California, will receive sealed bids for the **West Marin Elementary School Septic System Repairs Project** (“Project”) up to, but not later than, **11:00 a.m., on Tuesday, July 11, 2017**, and will thereafter publicly open and read aloud the bids. All bids shall be received at the office of the Shoreline Unified School District, 10 John Street, Tomales, California.
2. Each bid shall be completed on the Bid Proposal Form included in the Contract Documents, and must conform and be fully responsive to this invitation, the plans and specifications and all other Contract Documents. Copies of the Contract Documents are available for examination at the office of Greystone West Company, Sonoma, California, and may be obtained by licensed contractors by emailing Courtney Jackson at courtney@greystonewest.com.
3. Each bid shall be accompanied by cash, a cashier's or certified check, or a bidder's bond executed by a surety licensed to do business in the State of California as a surety, made payable to the District, in an amount not less than ten percent (10%) of the maximum amount of the bid. The check or bid bond shall be given as a guarantee that the bidder to whom the contract is awarded will execute the Contract Documents and will provide the required payment and performance bonds and insurance certificates within ten (10) days after the notification of the award of the Contract.
4. The successful bidder shall comply with the provisions of the Labor Code pertaining to payment of the generally prevailing rate of wages and apprenticeships or other training programs. The Department of Industrial Relations has made available the general prevailing rate of per diem wages in the locality in which the work is to be performed for each craft, classification or type of worker needed to execute the Contract, including employer payments for health and welfare, pension, vacation, apprenticeship and similar purposes. Copies of these prevailing rates are available to any interested party upon request and are online at <http://www.dir.ca.gov/DLSR>. The Contractor and all Subcontractors shall pay not less than the specified rates to all workers employed by them in the execution of the Contract. It is the Contractor's responsibility to determine any rate change.
5. The schedule of per diem wages is based upon a working day of eight hours. The rate for holiday and overtime work shall be at least time and one half.
6. The substitution of appropriate securities in lieu of retention amounts from progress payments in accordance with Public Contract Code §22300 is permitted.
7. Pursuant to Public Contract Code §4104, each bid shall include the name and location of the place of business of each subcontractor who shall perform work or service or fabricate or install work for the contractor in excess of one-half of one percent (1/2 of 1%) of the bid price. The bid shall describe the type of the work to be performed by each listed subcontractor.

9. Minority, women, and disabled veteran contractors are encouraged to submit bids. This bid is / is not subject to Disabled Veteran Business Enterprise requirements.
10. The project is subject to compliance monitoring and enforcement by the California Department of Industrial Relations. In accordance with SB 854, all bidders, contractors and subcontractors working at the site shall be duly registered with the Department of Industrial Relations at time of bid opening and at all relevant times. Proof of registration shall be provided as to all such contractors prior to the commencement of any work.
11. Each bidder shall possess at the time the bid is awarded the following classification(s) of California State Contractor's license: **“A” General Engineering Contractor OR “C42” Sanitation System Contractor.**
12. No Bidders’ Conference.

SHORELINE UNIFIED SCHOOL DISTRICT

By: Bruce Abbott
Chief Business Official

DATED: June 22, 2017

Publication Dates: 1) Monday, June 26, 2017 2) Monday, July 3, 2017

West Marin ES Septic Repairs

ID	Task Mode	Task Name	Duration	Start															
					J 11	J 18	J 25	J 2	J 9	J 16	J 23	J 30	A 6	A 13	A 20	A 27	S 3		
1		Advertisement Posted	1 day	Fri 6/23/17															
2		Mandatory Run Period	12 days	Fri 6/23/17															
3		Open Bids	1 day	Tue 7/11/17															
4		Award Contract	1 day	Wed 7/12/17															
5		Bonds & Insurance	6 days	Thu 7/13/17															
6		Notice to Proceed	1 day	Fri 7/21/17															
7		Mobilization	1 day	Mon 7/24/17															
8		Test & Repair Tanks	15 days	Tue 7/25/17															
9		Construct Field #3	14 days	Tue 8/8/17															
10		Inspect Tanks	2 days	Fri 8/11/17															
11		Inspect Field	2 days	Thu 8/24/17															
12		Demobilize	5 days	Mon 8/28/17															

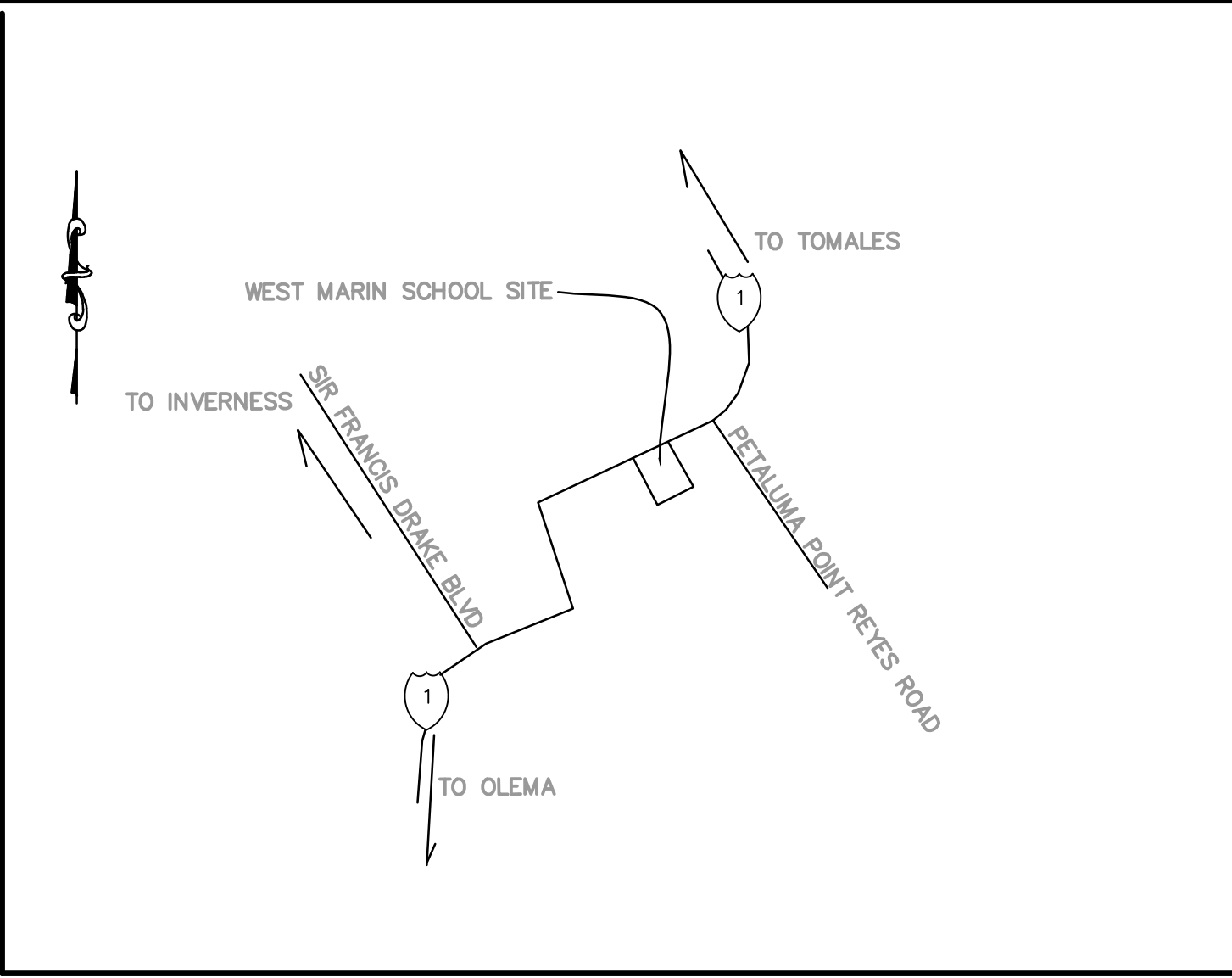
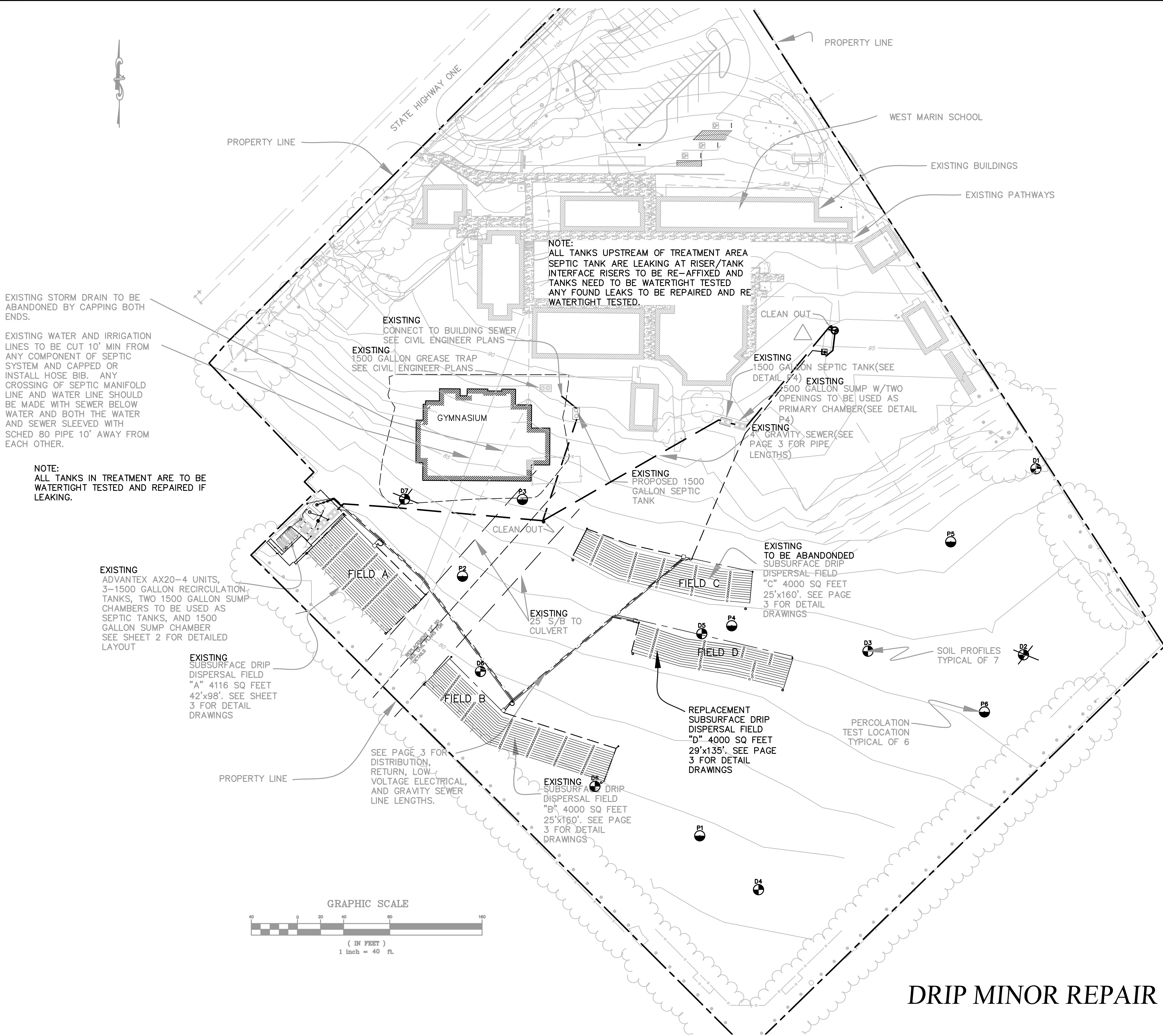

VICINITY MAP

NOTES:
 NOT TO BE USED AS BOUNDARY SURVEY, SURVEY PROVIDED BY CARLILE-MACY ENGINEERS/SURVEYORS, SANTA ROSA, CA
 SEE CIVIL PLANS FOR PROPOSED LOCATIONS OF OTHER SITE UTILITIES
 SEE ARCHITECTURE PLANS FOR EXACT LOCATIONS OF SEWER STUB FROM BUILDING
 NOTIFY ENGINEER 48 HOURS PRIOR TO BEGINNING CONSTRUCTION
 IN ADDITION TO A SEWAGE DISPOSAL PERMIT FROM MARIN COUNTY ENVIRONMENTAL HEALTH DEPARTMENT, OTHER PERMITS MAY BE REQUIRED FOR THE ELECTRICAL COMPONENTS. CONTRACTOR TO BE RESPONSIBLE FOR GAINING ELECTRICAL PERMIT FOR THE SEPTIC SYSTEM FROM THE BUILDING DEPARTMENT
 IN AREAS WHERE DISPERSAL FIELDS ARE PROPOSED CONTRACTOR TO REMOVE ALL IRRIGATION A MINIMUM OF 10' AWAY FROM NEW DISPERSAL FIELD
 THIS SYSTEM IS DESIGNED FOR SEWAGE STRENGTH WITH THE FOLLOWING CHARACTERISTICS
 BOD ≤ 200 mg/L, GREASE AND OIL ≤ 20 mg/l
 DIALY FLOW ≤ 3600 GALLONS PER DAY
 SHOULD ANY OF THE PARAMETERS BE EXCEEDED ADDITIONAL TREATMENT MAY BE NECESSARY.

- LEGEND:**
- NEW GRAVITY SEWER PIPES
 - DRIP DRAINFIELD
 - PROPOSED NEW BUILDING
 - WASTEWATER JOINT TRENCH
 - HEADWORKS BOX
 - SETBACK LINE
 - STORMDRAIN

- ABBREVIATIONS**
- S/B SETBACKS
 - SS SANITARY SEWER
 - PL PROPERTY LINE
 - SD STORMDRAIN

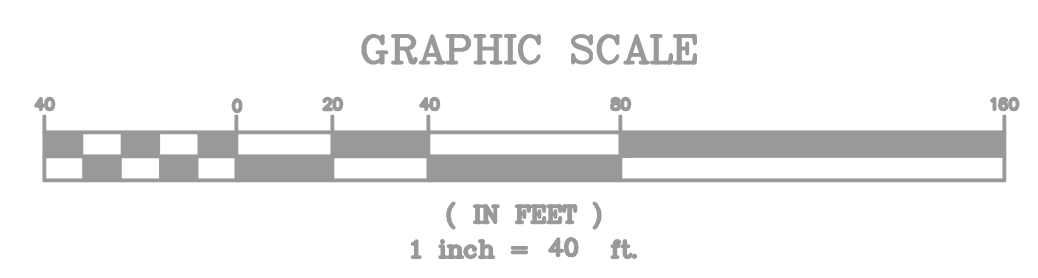

DRIP MINOR REPAIR

Revisions:	
PREPARED FOR:	SHORELINE SCHOOL DISTRICT PO BOX 198 TOMALES, CA 94971
Onsite Wastewater Treatment System	West Marin School Point Reyes Station, CA
AYS Engineering Group, Inc	131 Liberty St, Petaluma, CA 94952 Voice (707) 763-6620, Fax (707) 763-6629
Job No. 2001-063	Date 5/17/02
Drawn By: TKP	Checked By:
Scale 1" = 40'	Sheet 1 of 2
1	1

C:\MONITORING\2005-020-repairs\2001-063-rosenthal\as_built\SEPTIC SYSTEM DESIGN.dwg, anvanter treatment areaP1, 6/22/2017 7:18:28 AM, 1:1:0005

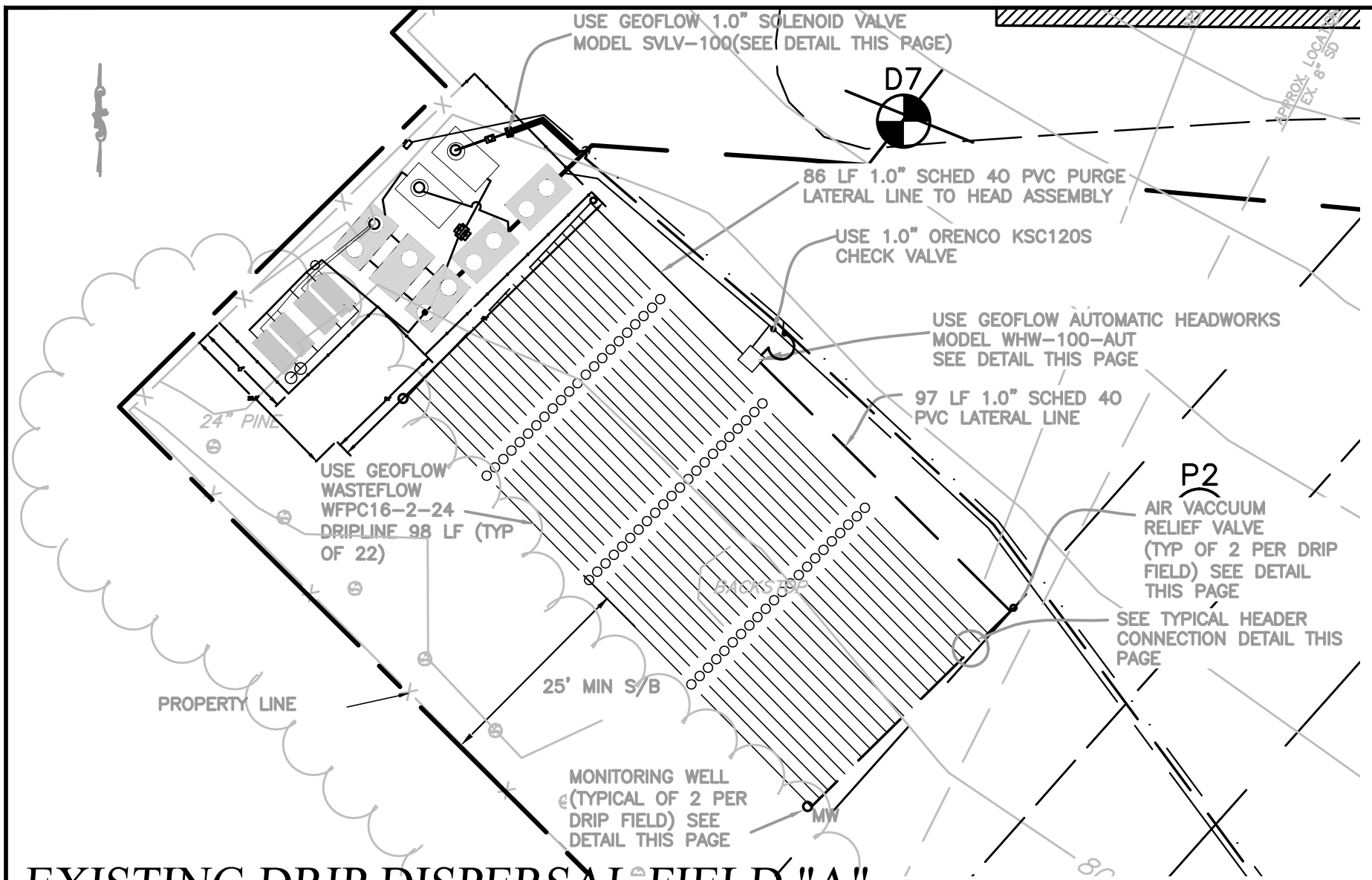

EXISTING DRIP DISPERSAL FIELD "A"
SCALE 1"= 20'

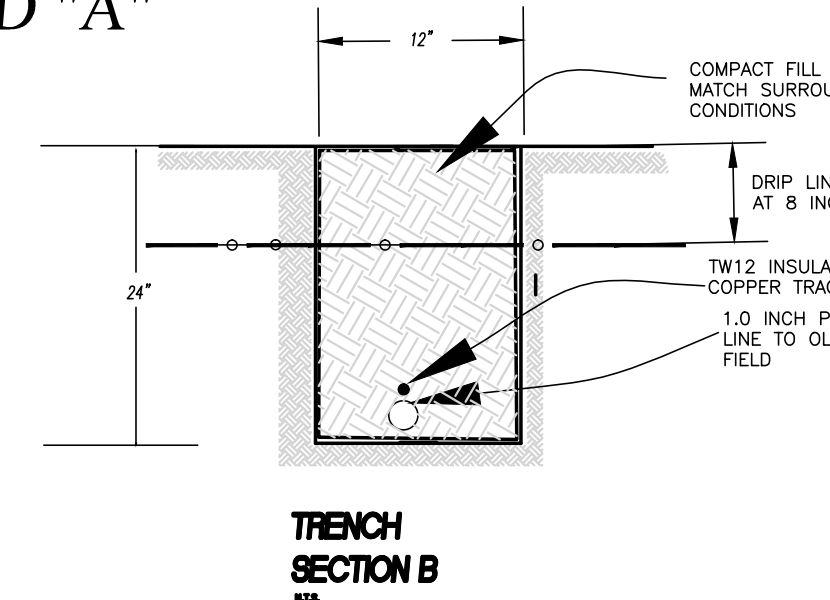
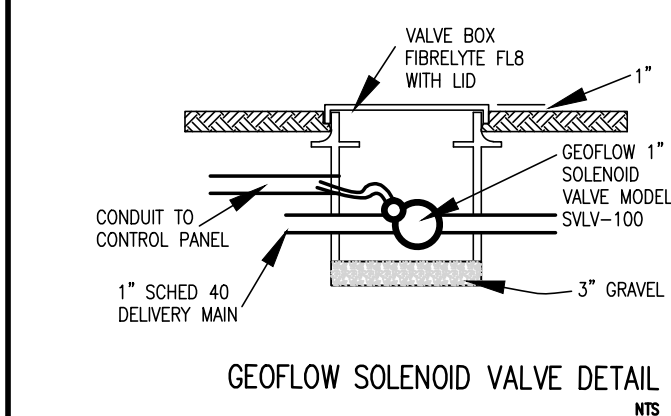

TRENCH SECTION B

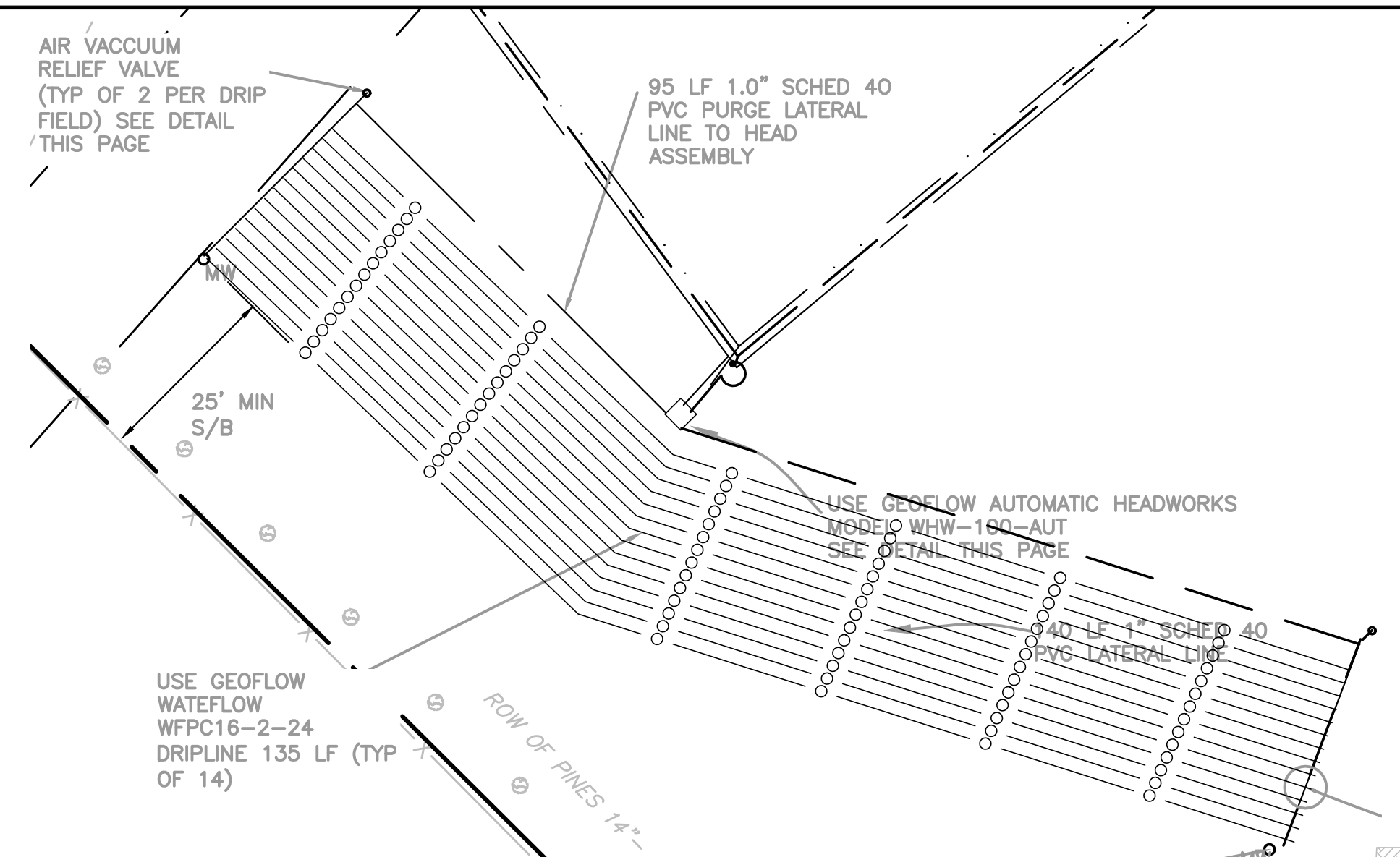

EXISTING DRIP DISPERSAL FIELD "B"
SCALE 1"= 20'

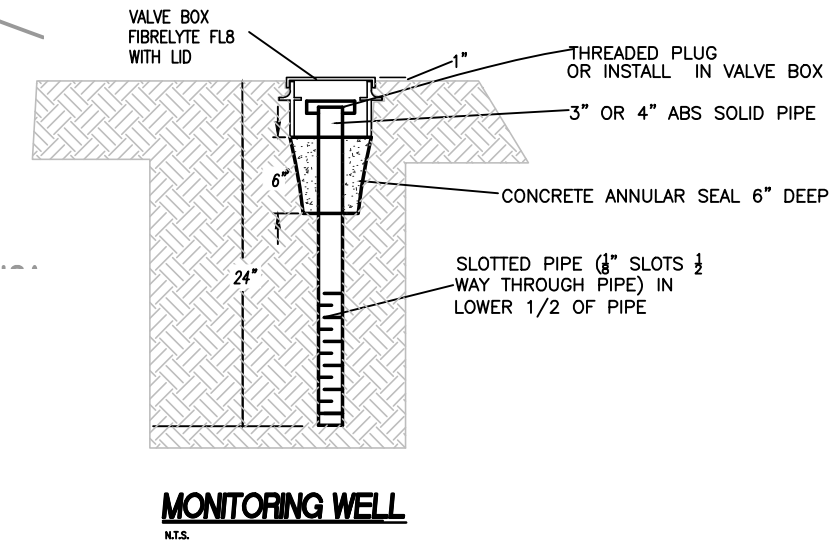

MONITORING WELL

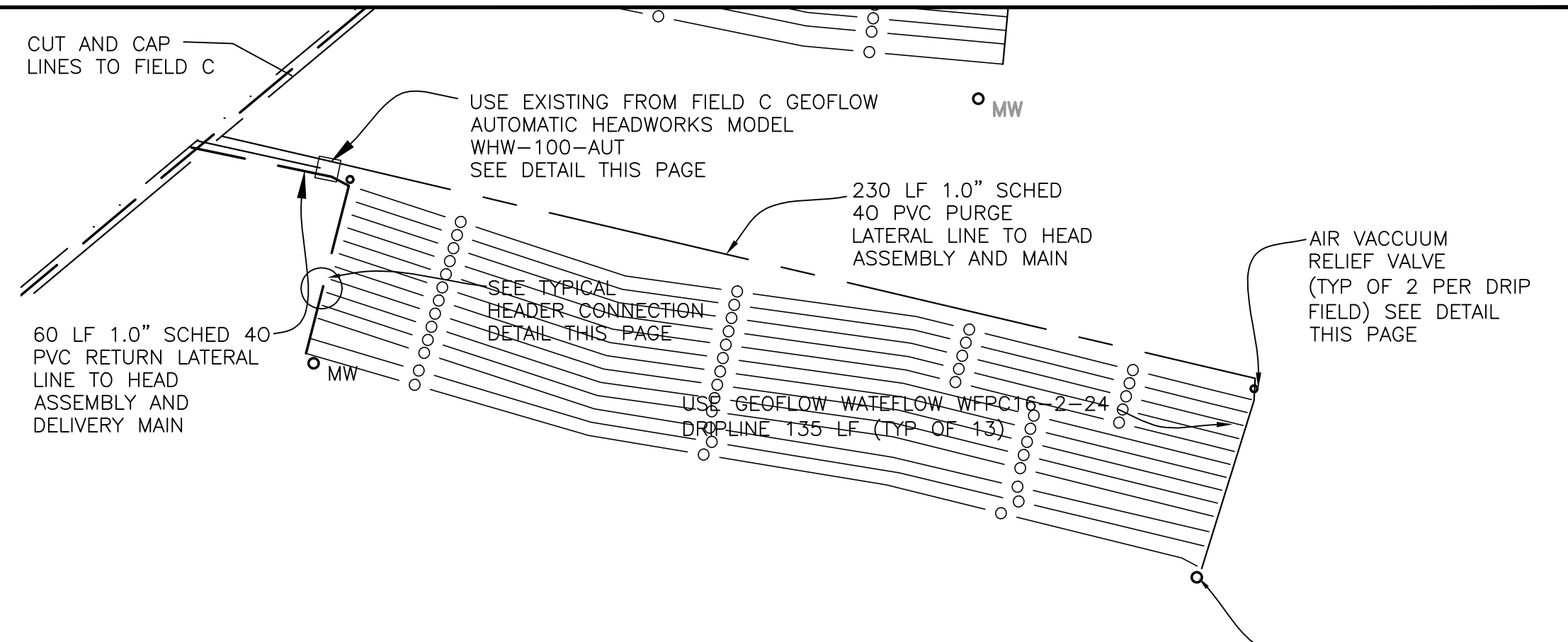

NEW DRIP DISPERSAL FIELD "D"
SCALE 1"= 20'

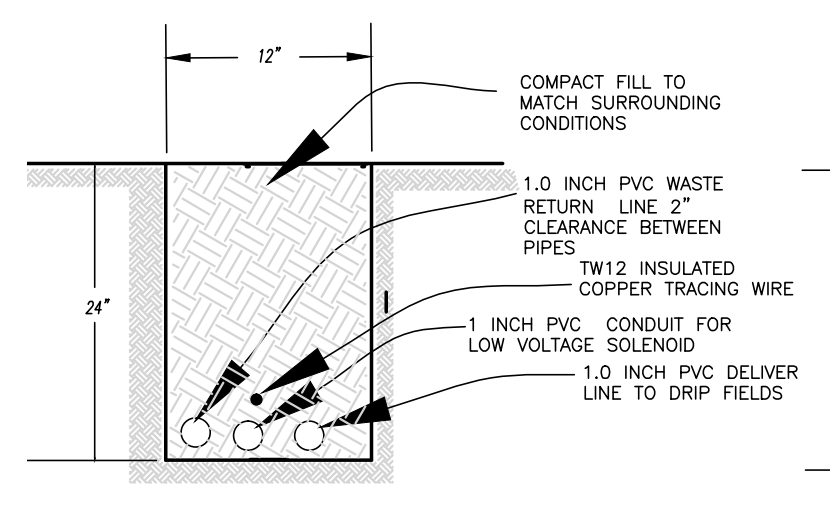

TRENCH SECTION A

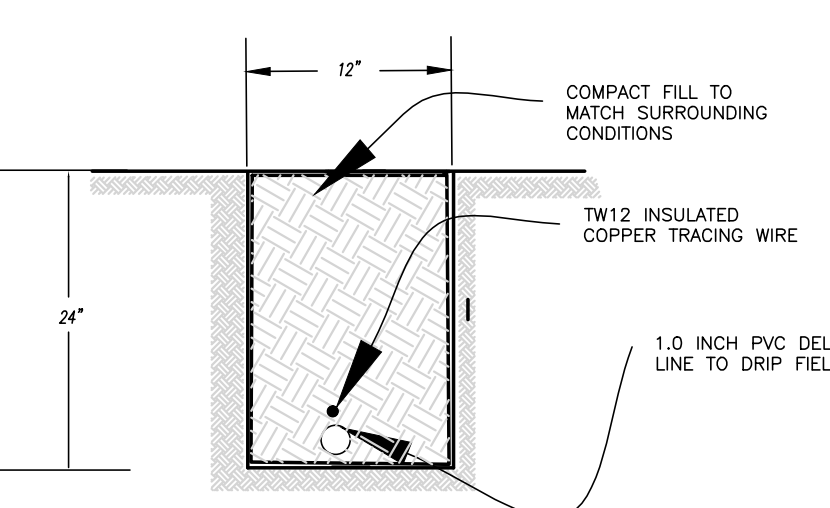

TRENCH SECTION C

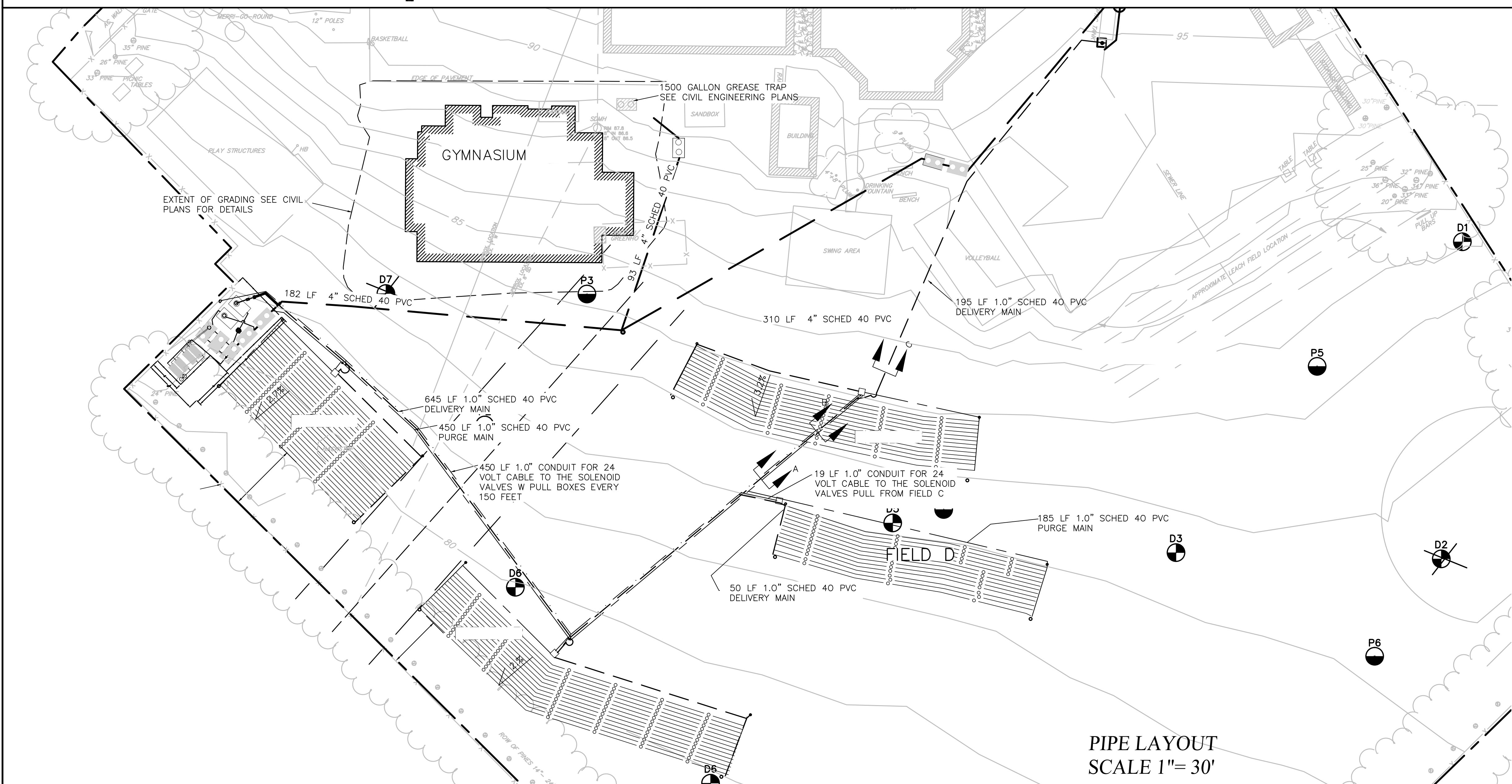

PIPE LAYOUT
SCALE 1"= 30'

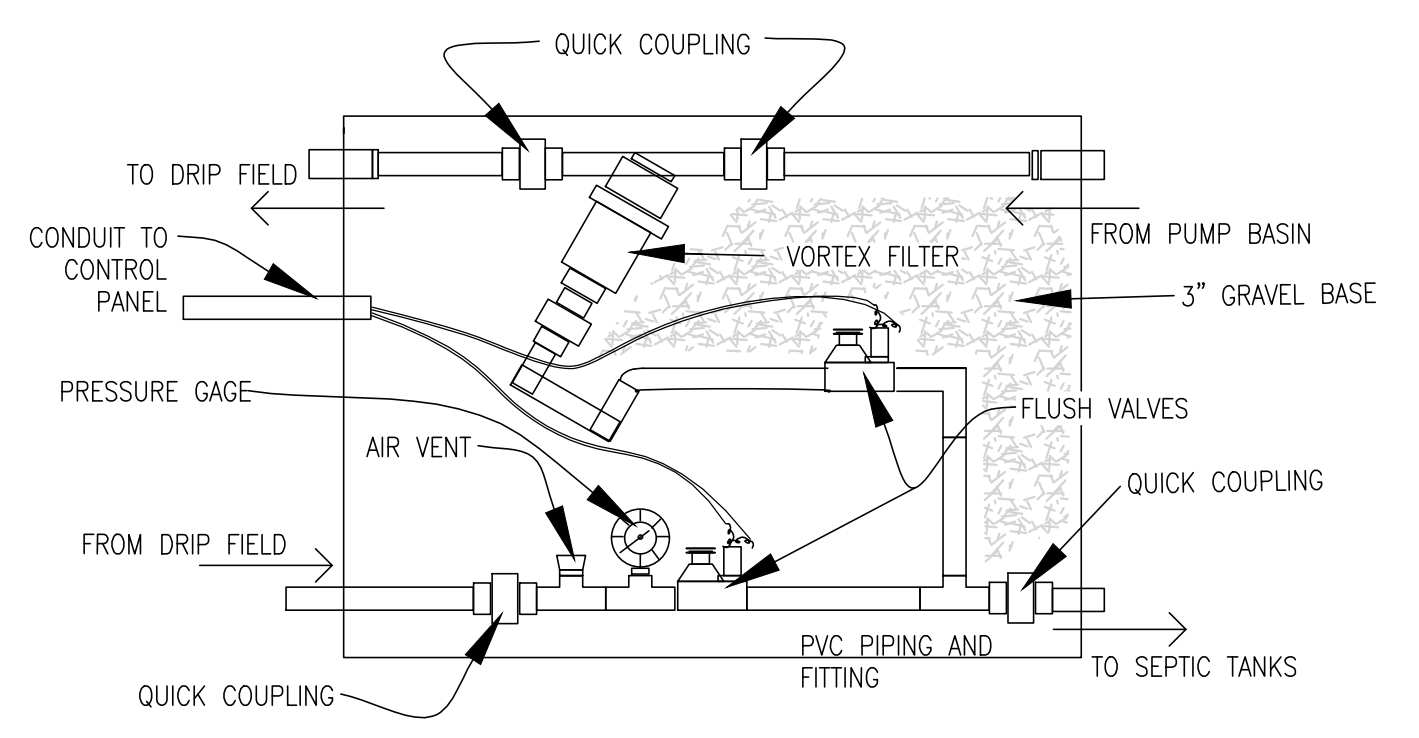

AUTOMATIC HEADWORKS WHW-100-AUT NTS

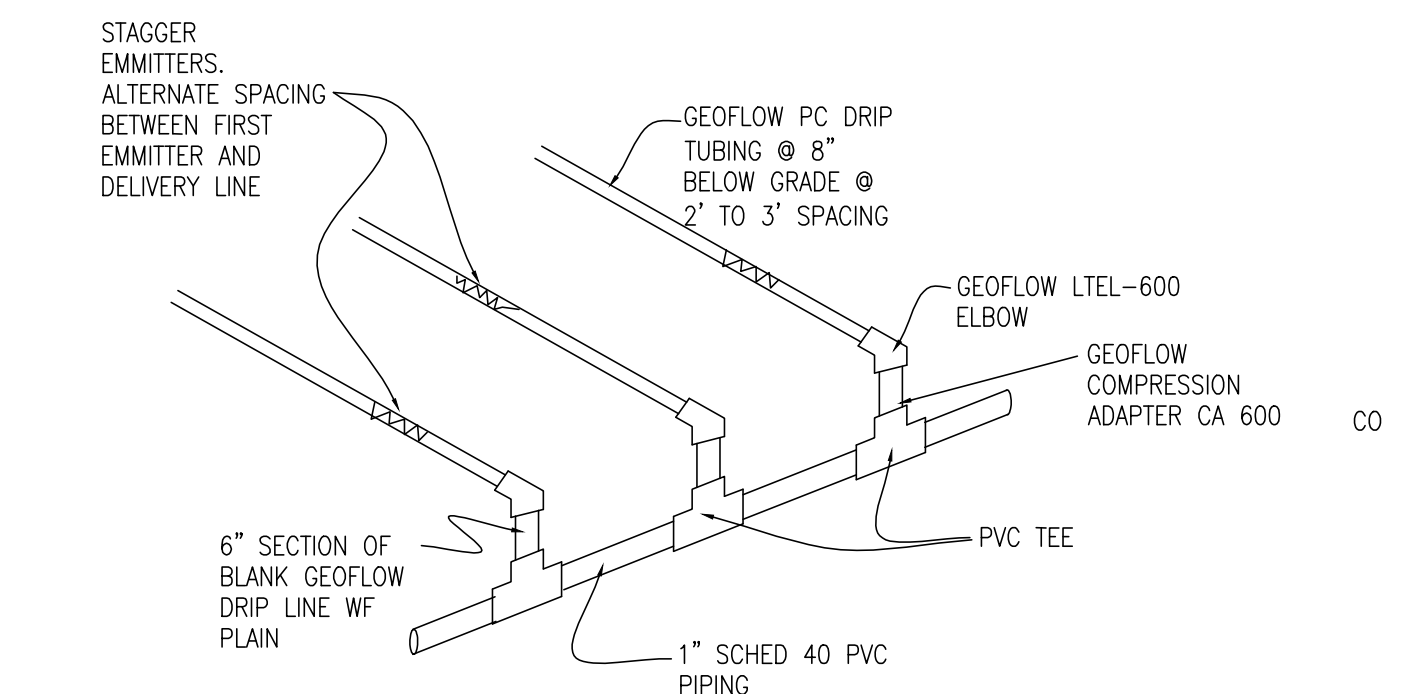

TYPICAL HEADER CONNECTION NTS

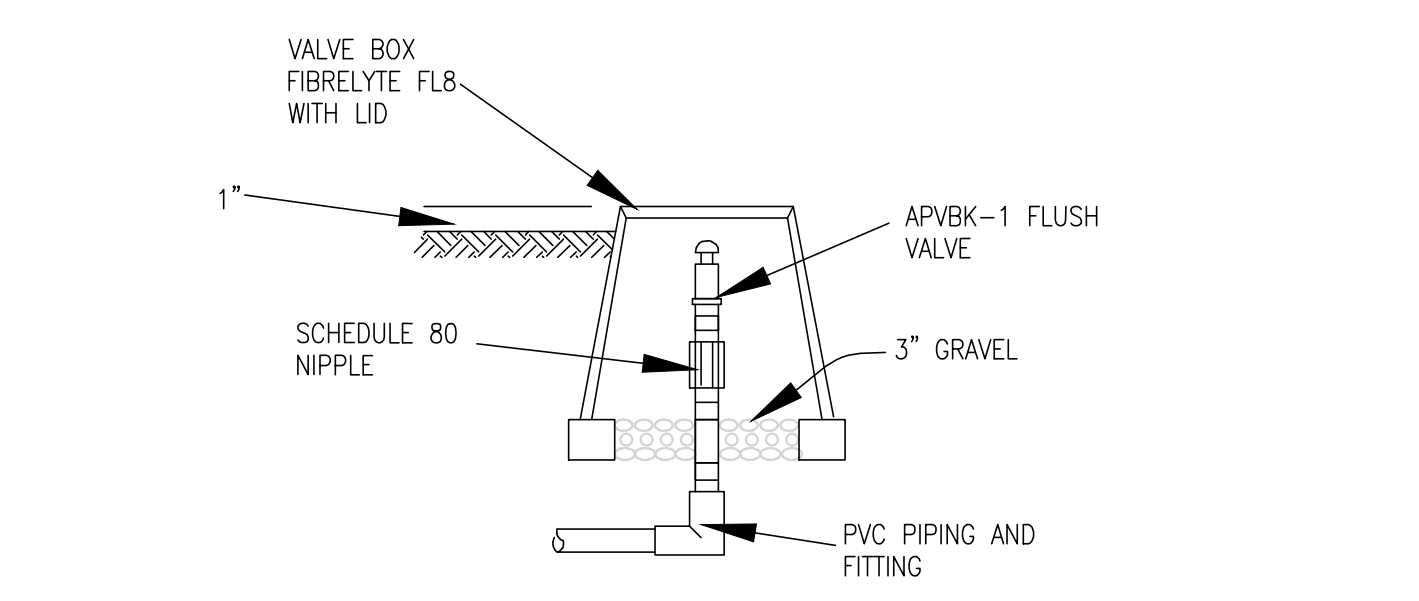

1" AIR/VACCUUM RELIEF IN VALVE BOX NTS

Revisions:

PREPARED FOR:
SHORELINE SCHOOL DISTRICT
PO BOX 198
TOMALES, CA 94971

Onsite Wastewater Treatment System
West Marin School
Point Reyes Station, CA

AYS Engineering Group, Inc
131 Liberty St, Petaluma, CA 94952
Voice (707) 763-6620, Fax (707) 763-6629

Job No:
2001-063
Date:
5/20/02
Drawn By:
TKP
Checked By:
PRE
Scale:
AS SHOWN

Sheet 2 of 2

C:\MONITORING\2002-020-reseal\2001-063-rosenthal\as_built\SEPTIC_SYSTEM_DESIGN.dwg, DRIP_LAYOUT.PLT, 6/22/2017 7:19:36 AM, 1:100000

GENERAL NOTES

- CONTRACTOR TO NOTIFY MARIN COUNTY ENVIRONMENTAL HEALTH SERVICES (MCEHS) PERSONEL AND DESIGN ENGINEER 48 HOURS PRIOR TO BEGINNING CONSTRUCTION.
- TOPOGRAPHIC SURVEY PROVIDED BY CARLILE-MACY ENGINEERS/SURVEYORS, SANTA ROSA, CA.
- NOT TO BE USED AS A BOUNDARY SURVEY- SURVEYOR TO STAKE ALL PROPERTY LINES AND EASEMENTS.
- MAINTAIN 10' SEPARATION FOM ANY SEWAGE LINE TO WATERLINE IF NOT POSSIBLE REROUTE TO MAINTAIN SEPARATION. CROSSING SHALL BE MADE WITH WATER ABOVE SEWER LINE WITH A 1' SEPARATION AND CONCRETE BETWEEN LINES.
- NO CUTS SHALL BE MADE DOWNSLOPE OF DRAINFIELD WITHOUT PERMISSION OF BOTH MCEHS AND DESIGN ENGINEER.
- CONSULT ENGINEER PERTAINING TO LANDSCAPING IN SEPTIC SYSTEM AREA.
- NO MATERIAL SUBSTITUTION WITH OUT DESIGN ENGINEER APPROVAL.
- NO WORK TO BE PERFORMED DURING WET CONDITIONS AND ALL EXCAVATION TO BE COORDINATED WITH THE DESIGN ENGINEER AND MCEHS STAFF PERSON DURING WET SEASON (OCTOBER 15- APRIL 15)
- ALL TANKS TO BE WATERTIGHT-SEE WATERTIGHTNESS TEST.
- CONTRACTOR NOT TO OVEREXCAVATE THE DELIVERY LINE TRENCH/S. MAXIMUM DEPTH OF TRENCH IS 24 INCHES.
- EROSION PROTECTION SHALL BE PLACED IN ALL DISTURBED AREAS. STRAW AND SEED SHALL BE PLACED AT A MINIMUM PROIR TO FINAL INSPECTION.
- ALL PLUMBING FIXTURES TO BE LOW FLOW 1.6 GAL FLUSH TOILETS AND 2 GAL/MIN SHOWER HEADS.
- ALL SEWER LINES FROM BUILDINGS SHALL BE 4 INCH SCH 40 PVC OR APPROVED EQUIVALENT WITH A MINIMUM SLOPE OF 2 PERCENT. INSTALL CLEANOUTS AT CHANGES IN DIRECTION AND 5 FEET FROM THE OUTSIDE OF THE BUILDING.
- ALL WORK SHALL BE IN CONFORMANCE WITH THESE PLANS AND THE MOST RECENT REGULATIONS FOR WASTEWATER SYSTEMS.
- CONTRACTOR TO KEEP A COUNTY STAMPED SET OF PLANS AT THE JOBSITE AND A SET WITH ALL AS BUILT CHANGES MARKED UP AT THE JOB SITE AT ALL TIMES. THE CONTRACTOR TO PROVIDE ONE COPY OF THESE CHANGES ON A PLAN FOR PREPARATION OF AS-BUILT DRAWINGS TO GAIN COUNTY FINAL APPROVAL.
- ENGINEER WILL PROVIDE GEOFLOW DESIGN AND INSTALLATION MANUAL FOR ADDITIONAL INFORMATION.
- ALL INSTALLATION INSTRUCTIONS IN THE GEOFLOW DESIGN AND INSTALLATION MANUAL SHALL BE FOLLOWED WHEN NOT CONFLICTING WITH THESE PLANS.

CONSTRUCTION INSPECTION NOTES

CONTRACTOR TO NOTIFY DESIGN ENGINEER AND MARIN COUNTY ENVIRONMENTAL HEALTH SERVICES A MINIMUM OF 48 HOURS PRIOR TO CONSTRUCTION AND INSPECTION OF THE SYSTEM. ADDITIONAL FEES WILL BE REQUIRED BY COUNTY OF MARIN AFTER THREE SITE INSPECTIONS. ENGINEER AND MARIN COUNTY ENVIRONMENTAL HEALTH SERVICES SHALL INSPECT THE SYSTEM AT CRITICAL CONSTRUCTION PHASES AS FOLLOWS:

PHASE ONE:

- INSPECT STAKE OUT LOCATION OF DRIP LINES, THE SEPTIC SUMP TANKS AND ADVANTEX UNITS AS SHOWN ON THE PLANS. DRIP LINES TO BE LAID OUT ON COUNTOUR.

PHASE TWO:

- INSPECT THE DRIP LINES AND ADVANTEX COMPONENTS FOR CLEANLINESS AND FUNCTIONALITY.

PHASE THREE:

- INSPECT DRIP INSTALLATION AND LEVEL AND INSTALLED INSPECTION WELLS.
- INSPECT VACCUM RELIEF VALVE INSTALLATION.
- INSPECT DRIP TUBING AND ADVANTEX LOCATIONS
- INSPECT WATERTIGHTNESS OF ALL TANKS.
- INSPECT PRESURIZATION OF ALL DRIP FIELDS.

PHASE FOUR:

- INSPECT CONTROL PANEL, FLOATS AND CIRCUIT BREAKERS FOR ENTIRE SEPTIC SYSTEM.
- INSPECT ANY ITEMS LISTED ABOVE WHICH HAVE NOT BEEN OBSERVED YET.

PHASE FIVE:

- PROVIDE M.C.E.H.S WITH BUILDING DEPARMENT APPROVAL OF PUMP INSTALLATION.
- INSPECT FINISHED SEPTIC SYSTEM INCLUSIVE OF ANY NECESSARY EROSION CONTROL MEASURES.
- INSPECT FLOOR PLAN OF ALL STRUCTURES BEING SERVED BY THE SEPTIC SYSTEM. INSPECT WHETHER LOW FLOW FIXTURES WERE INSTALLED IN NEW FACILITIES. INSPECT WHETHER EXISTING FACILITIES WERE RETROFITED WITH LOW FLOW FIXTURES.

OPERATION AND MAINTENANCE OF A SEPTIC SYSTEM

- INSPECT THE VORTEX FILTER AFTER 10 DAYS OF USAGE.
- INSPECT SEPTIC TANKS AND DRAINFIELD EVERY SIX MONTHS.
- IF SLUDGE OR SCUM BUILDUP IS GREATER THAN 6 TO 8 INCHES HAVE TANK PUMPED. (USUAL FREQUENCY FOR PUMPING IS 3 TO 5 YEARS)
- MINIMIZE THE USE OF GARBAGE DISPOSAL.
- MINIMIZE THE USE OF HARSH CHEMICALS IN LARGE QUANTITIES.
- MINIMIZE THE AMOUNT OF GREASE DISPOSED OF IN SINKS. PACKAGE ALL FOOD WASTES AND DISPOSE OF IN GARBAGE FOR SANITARY LANDFILL.
- MINIMIZE DISPOSAL OF NON-SEWAGE ITEMS SUCH AS SANITARY NAPKINS, CIGARETTES AND OTHERS.
- MAINTAIN ALL PLUMBING. LEAKS SHOULD BE FIXED AS QUICK AS THEY OCCUR.
- MINIMIZE LIQUID LOAD ON THE SYSTEM BY WASHING DISHES IN LARGE LOADS.
- PROHIBIT VEHICULAR TRAFFIC AND HOOFED ANIMALS FROM THE SEPTIC SYSTEM AREA.

PUMP:

THE PUMP SHALL BE OF THE SIZE AND TYPE INDICATED ON THE PLANS AND SHALL INCLUDE THE FOLLOWING:

- A HANDS OFF AUTO (HOA) SWITCH.
- AN AUDIO AND VISIBLE ALARM AND NECESSARY EFFLUENT SENSING DEVICE TO INDICATE A HIGH WATER CONDITION.
- SET PUMPING VOLUME AS STATED IN THE PUMP REQUIREMENTS.
- PUMP TO BE SET A MINIMUM OF 4 INCHES FROM THE BOTTOM OF THE SUMP.

SUMP:

- THE SUMP SHALL HAVE A WORKING CAPACITY OF 1.5 TIMES THE DESIGN FLOW DESIGNATED. THE CAPACITY SHALL INCLUDE THE DOSE VOLUME AND 24-HOUR STORAGE VOLUME.
- ACCESS TO BE PROVIDED BY A MINIMUM 24-INCH DIAMETER WATERPROOF AIRTIGHT RISER AND LID SYSTEM.
- ALL PIPE AND OR ELECTRICAL CONNECTIONS MADE THROUGH THE RISER EITHER TO BE PRECAST INTO THE RISER OR SEALED WITH GASTIGHT COMPRESSION CONNECTORS.

ELECTRICAL FEATURES

THE FOLLOWING ELCTRICAL FEATURES TO BE PROVIDED

- AN OUTDOOR TYPE CONTROL BOX CONTAINING A FUSED DICONNECT AND MOTOR PROTECTION SWITCH. SEE THE PUMP REQUIREMENT SECTION OF THE PLANS FOR THE MODEL NUMBER AND REQUIREMENTS.
- THE CONTROL BOXES TO BE MOUNTED ON A 4"x4" POST THAT IS INSTALLED SECURELY AT THE LOCATIONS SHOWN. (SEE SHEET 2)
- ALARM AND PUMP TO BE INSTALLED ON SEPARATE CIRCUITS THAT ARE OF SIZE LARGE ENOUGH FOR THE RESPECTIVE USES.
- ELECTRICAL CONDUIT SHALL BE PVC AND SEPARATE CONDUITS SHALL BE PROVIDED TO POWER PUMP AND FLOATS.
- HIGH WATER AUDIO AND VISIBLE ALARM SHALL BE LOCATED IN THE SCHOOL MAIN OFFICE AND MAINTENANCE OFFICE.
- TELEMETRY PANEL REQUIRED ORENCO MODEL VCOM-DAX/DAX2PTROCS DRIP W/4 ZONES

PRESSURE PIPING

- THE PIPE FROM THE SUMP TO THE DRAINFIELD SHALL BE PVC SCHEDULE 40 PIPE IN THE SIZE SPECIFIED ON THE PLANS.
- A UNION SWING CHECKVALVE AND DOUBLE WEDGE GATE VALVE SHALL BE INSTALLED IN THE SUMP CHAMBER IN THIS ORDER AWAY FROM THE PUMP. ALTERNATIVELY THESE ITEMS CAN BE INSTALLED IN A VALVE BOX NEXT TO THE SUMP CHAMBER.
- CONCRETE THRUST BLOCKS SHALL BE INSTALLED WHEN CHANGE IN PIPE DIRECTION IS 45 DEGREES OR GREATER.

PERMITS

ASIDE FROM THE INDIVIDUAL SEWAGE DISPOSAL SYSTEM PERMIT ADDITIONAL PERMIT (S) WILL BE REQUIRED BY THE BUILDING INSPECTION DEPARTMENT FOR PUMP INSTALLATION.

TANK WATERTIGHTNESS TEST

- CAP OR TEST PLUG ALL INLETS AND OUTLETS TO TANK.
- FILL TANK WITH WATER TWO INCHES INTO THE RISER AND MARK WATER LEVEL. SCHEDULE WITH ENGINEER AND NECM 24 HOURS BEFORE FILLING TANK.
- IF AFTER 24 HOURS WATER LEVEL DROPS, TANK MUST BE MADE WATERTIGHT BY APPLYING WATERPROOF SEALER (NOT BITMEOUS PRODUCT) THOROPLUG, THOROSEAL OR OTHER PORTLAND CONCRETE CEMENT PRODUCT.

PUMP REQUIREMENTS

PS#1 TO ADVANTEX (DUPLEX PUMPS)

TOTAL DYNAMIC HEAD =27.5 FT
GALLONS PER MINUTE (GPM) =47
TIMER FUNCTIONS:
ON 36 SECONDS, OFF 6.12 MIN
RECOMMENDED PUMP TYPE: ORENCO P500512, 7.3 AMP 230 VAC, IN DUPLEX 14.6 AMP TOTAL
OR EQUIVALENT
RECOMMENDED CONTROL PANEL:
ORENCO VCOM-DAX/DAX2 PTROCS/PTROCS DRIP W/4 ZONES TO CONTROL PS#1,2&3

PS#2 TO LF DRIP LEACHFIELDS

TOTAL DYNAMIC HEAD = 112.7 FT
GALLONS PER MINUTE (GPM) = 8.83
DOSE = 333 GALLONS
OPERATION RANGE = 12"
RECOMMENDED PUMP TYPE: ORENCO P300712, 230VAC, 8.8 AMP
RECOMMENDED CONTROL PANEL:
SEE ABOVE
CONTROL PANEL SETTINGS:
BASED ON A FLOW OF 8.83 GPM
OFF 122 MIN 20 SEC
ON 37 MIN 45 SEC

VORTEX FILTER FLUSH VALVE TO OPEN 1 MIN 15 SEC BEFORE END OF PUMP CYCLE FOR A DURATION OF 1 MIN.

FIELD FLUSH VALVE TO OPEN FOR THE FINAL 15 SEC OF THE PUMP CYCLE.

ALTERNATE BETWEEN FIELDS A, B & C EACH CYCLE

PS#3 TO SEPTIC TANKS

TOTAL DYNAMIC HEAD = 14 FT
GALLONS PER MINUTE (GPM) = 20
DOSE = 656 GALLONS
OPERATION RANGE = 21"
RECOMMENDED PUMP TYPE: OSI PEF4021 115VOLTS, 5.9 AMP
RECOMMENDED CONTROL PANEL:
SEE ABOVE

Requirements & Settings for Control Panel at West Marin School

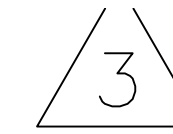

The West Marin School septic system requires an Orenco VCOM control panel that can meet the following requirements:

PS#1

To control 2 Orenco P500511 pumps in duplex (26.4 amp total at 115 Volts) to dose the advanTEX pods. The station will run on a timer but includes an override timer, low water redundant off and a high water alarm. Timer settings are as follows:
Pump ON = 0.6min or 36s
Pump OFF= 6.12 m or 6m 7s
Cycle Time= 7.72m or 6m 43s

PS#2

To control 1 Orenco P100511 (12amp at 115V) to alternate dosing between drip fields A, B & C. The station houses an alarm float, pump ON float and redundant OFF float. When the water level reaches the ON float the pump turns ON and the geoflow solenoid valve for the field receiving the dose opens for the entire duration of the pump run time. The pump will run for a time of 36.8min or 36m 48s. After the pump has run for 35m 33s the filter flush valve for the field being dosed will open for 1 min closing at 36m 33s. The field flush valve is to open for the last 15 seconds of the pump run time opening at 36m 33s and closing at 36m 48s. When the water again reaches the ON float the process is repeated for the next respective field. A fourth drain field solenoid valve is to be included in the event of an emergency. This emergency drainfield has no filter flush valve or field flush valve. Furthermore, the control panel must be capable of adding to or removing from its dosing rotation, any of the four drain fields.

PS#3

To contol 1 PEF4021 (5.9amps at 115V) for emergency overflow. Station has an alarm/pump ON float and a pump OFF float to turn the pump on and off.

FAN

To supply not less than 1 amp at 115 Volts to the FR150 forced ventilation system.

UV

To supply not less than 1 amp at 12 Volts to each of 2 Salcor UV units. Indication of wether light is ON or OFF is to be included in telemetry.

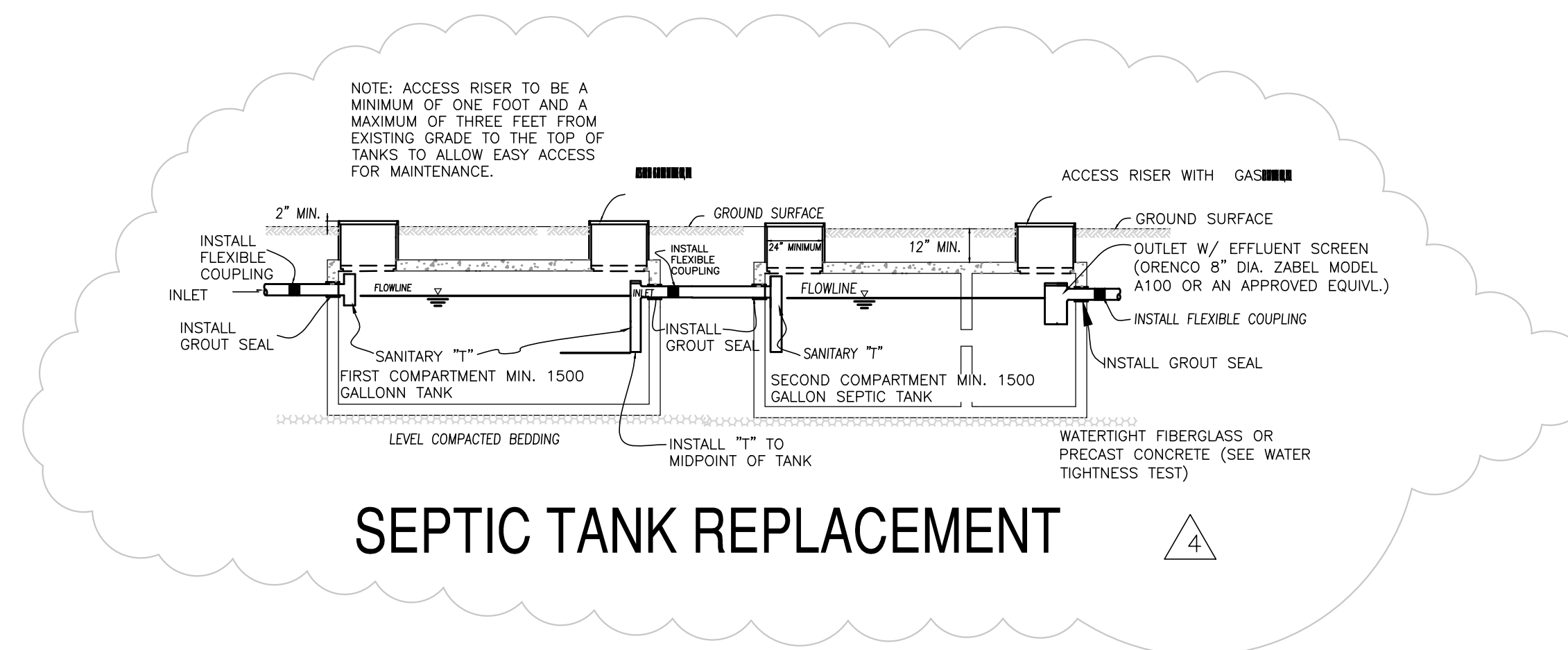

SEPTIC TANK REPLACEMENT

Date 6/22/2017
Project

West Marin School onsite system repair

Job# 2003-020

Engineers Opinion of Probable Cost

Replacement for Field 3

1 Ea	4000 Sq Ft drip dispersal field 139' x 29'	\$15000-\$20000	\$20,000.00
------	--	-----------------	-------------

Tanks at the gym and the play ground

4 Ea	watertight test, new risers, seal inlet-outlet	\$4,000.00	\$16,000.00
4 Ea	sealing of the cold seal should it be found to be leaking	\$2,000.00	\$8,000.00

Tanks in the treatment area

7 Ea	watertight test, new risers, seal inlet-outlet	\$4,000.00	\$28,000.00
7 Ea	sealing of the cold seal should it be found to be leaking	\$2,000.00	\$14,000.00

So a worst case might be that all of the risers need to be replaced, all of the inlets and outlets need to be resealed, and and the cold joint needs to be resealed in all of the tanks.

expected cost	\$86,000.00
---------------	-------------

It is possible that we also find some of the tanks need to be replaced (not likely but possible)

replace 1500 gallon tank risers and connect	\$7,000.00
---	------------

This opinion of cost was requested by the owner before the extent of the leaking tanks are known and as such is a rough example of the costs of construction.